

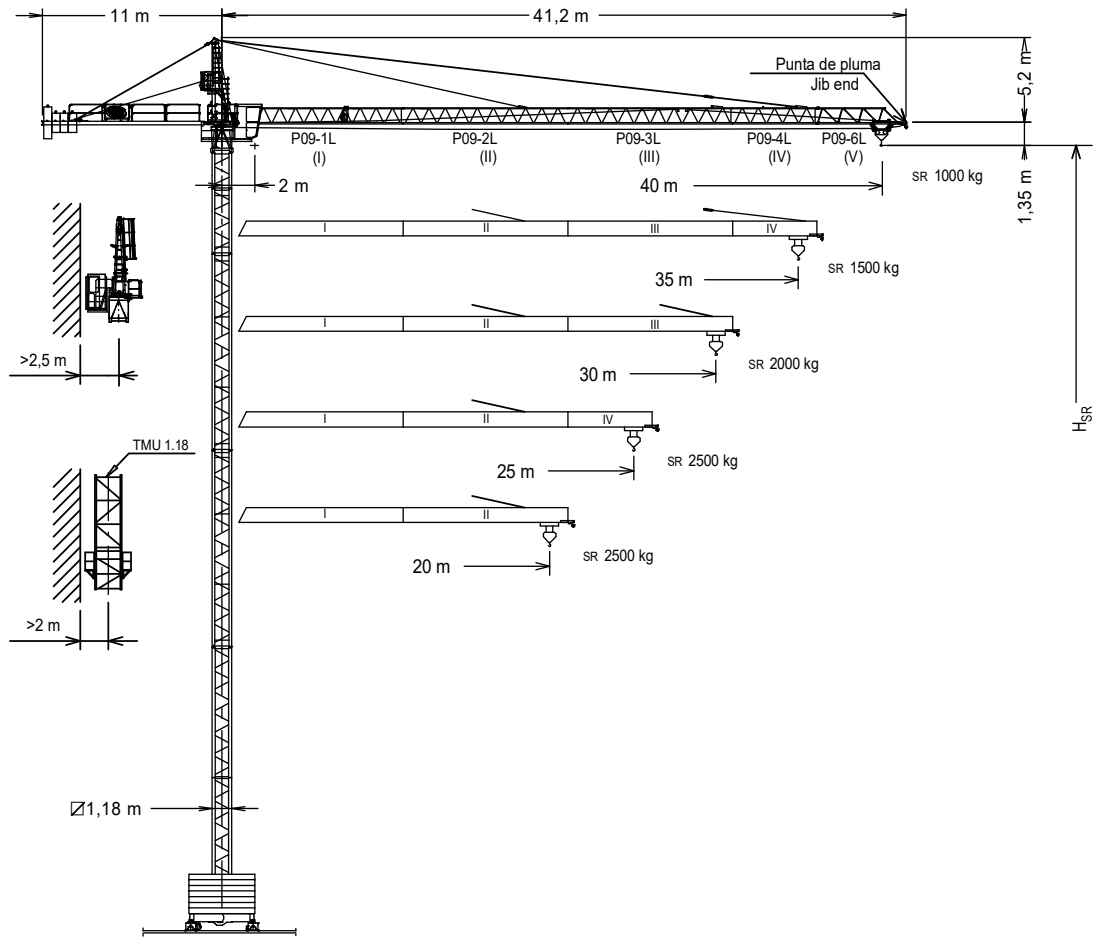

UNE 58-101
FEM 1001

UNE-EN-ISO 9001



Altura máxima bajo gancho sin arriostrar (m).
Maximum height under hook without fastening (m).
Hauteur maximale sous crochet sans ancrage (m).
Максимальная высота под крюком без крепления (m).
Bağlantısız maksimum kanca altı yüksekliği (m).
أقصى ارتفاع تحت الخطاف بدون ربط (m)

H_{SR} =



H_{SR} - 2 m.

TMU 1.18	202.35.500	AR12	137.21.000
P09-1L	155.40.000	AN 12	146.21.000
P09-2L	155.41.000	BTX 45/BEX 45	137.20.500
P09-3L	155.42.000	BTX 38R/BEX 38R	137.20.000
P09-4L	155.43.000	BTX 38/BEX 38	149.20.000
P09-6L	154.44.500	BTX 28/BEX 28	149.20.500
Punta de pluma / Jib end*	155.45.000	BEX 45L	155.23.500
TR 12	146.30.000	BEX 38RL	155.23.800
TN 12	146.31.000	BEX 38L	155.23.000
TR 8RM	202.30.000	BEX 28L	155.23.200
TR 8M	146.30.800	ABH 75	152.23.000
TR 4	800.32.300	ABH 90	146.23.000
TN 4	146.32.000	BE 442	146.24.850
TN2	146.32.500	BE 434	146.24.950

* Punta de pluma / Jib end / Pointe de flèche / Конец стрелы / Вор усу / مقدمة الذراع

(H) TRASLACIÓN / TRAVELLING /

TRASLATION / ПЕРЕМЕЩЕНИЕ / RAY YÜRÜYÜŞLÜ / إزاحة

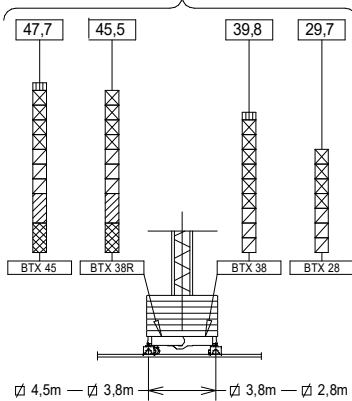

(H) ESTACIONARIA / STATIONARY /

STATIONAIRE / СТАЦИОНАРНОЕ СОСТОЯНИЕ / SABIT / ثابت

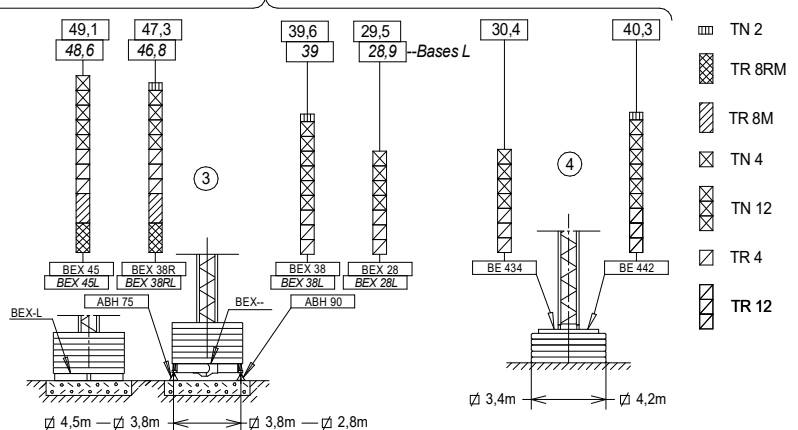



Fecha / Date: 28/04/2020





Reservado el derecho a modificaciones sin previo aviso. Declinamos toda responsabilidad derivada de la información proporcionada / Subject to modification, without previous warning. This information is supplied without liability / L'entreprise se réserve le droit de procéder à des modifications sans préavis. Nous déclinons toute responsabilité quant aux informations fournies / Мы оставляем за собой право на внесение изменений без предварительного уведомления. Мы снимаем с себя любую ответственность в отношении предоставленной информации / Önceden bildirilmeksizin değiştirilme hakkı saklıdır. Verilen bilgiler için hiçbir sorumluluk kabul etmemekteyiz حقوق التغيير محفوظة دون إشعار مسبق. دون أدنى مسؤولية عن المعلومات المقدمة

FEM 1001















CARGAS / LOADS / CHARGES / НАГРУЗКИ / YÜKLER / الأحمال **J4010**

	SR1 (kg)	Cargas máximas / Maximum loads / Charges maximales / Максимальные нагрузки / Maksimum yük / أقصى حمولة				
		SR1-2000 kg				
	2000 kg @...[m]	Alcance del gancho [m] / Hook reach [m] / Portée du crochet (m) / Радиус действия крюка (m) / Kancanın yüksekliği (m) / مدى الخطاف				
		20	25	30	35	40
40 m	22,2	2000	1750	1417	1179	1000
35 m	27,2	2000	2000	1792	1500	-----
30 m	30,0	2000	2000	2000	-----	-----
25 m	25,0	2000	2000	-----	-----	-----
20 m	20,0	2000	-----	-----	-----	-----



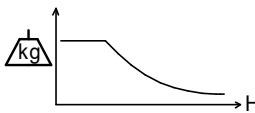

CARGAS / LOADS / CHARGES / НАГРУЗКИ / YÜKLER / الأحمال **J4010**

	SR2 (kg)	Cargas máximas / Maximum loads / Charges maximales / Максимальные нагрузки / Maksimum yük / أقصى حمولة				
		SR2-2500 kg				
	2500 kg @...[m]	Alcance del gancho [m] / Hook reach [m] / Portée du crochet (m) / Радиус действия крюка (m) / Kancanın yüksekliği (m) / مدى الخطاف				
		20	25	30	35	40
40 m	18,2	2250	1750	1417	1179	1000
35 m	22,3	2500	2200	1792	1500	---
30 m	24,6	2500	2450	2000	---	---
25 m	25,0	2500	2500	---	---	---
20 m	20,0	2500	---	---	---	---

CARACTERISTICAS DE MECANISMOS / MECHANISMS FEATURES / CARACTÉRISTIQUES DES MÉCANISMES / ХАРАКТЕРИСТИКИ МЕХАНИЗМОВ / MEKANİZMALARIN ÖZELLİKLERİ / الخصائص الآلية **J4010**

*opcional *optional *en option *опция *opsiyonel *اختياري								
	EC1846 SR2 13,2 kW	EC1856 SR1 13,2 kW	*EC2566VF SR2 18,4 kW	*EC2580VF SR1 18,4 kW	☑ 2,8 / 3,8 / 4,5m TG825VF 2x3 kW	OG608VF 4 kW	TC360 / *TC360VF 1,9 / *1,8 kW	TH1010 9,2 kW
	1,3 2,5 2,5 46 23 5	1,1 2 2 56 28 6	1,3 2,5 0..64 0..32	1,1 2 0..82 0..41	0...25 m/min	0... 0,8 r/min sl/min	30/60 m/min *0...30 *30...60 m/min	1 m/min
	H ≤ SR 193 m		SR 189 m		 P_{TOTAL} (EC1846/EC1856 + OG608VF + TC360) = 19,1 kW P_{TOTAL} (*EC2566VF/*EC2580VF + OG608VF + *TC360VF) = *24,2 kW 400V 50Hz			
					 EC1846 EC1856 TC360 TH1010 kW +20% m/min +20% 480V 60Hz			

LASTRES INFERIORES / LOWER BALLASTS / LESTS INFÉRIEURS / НИЖНИЙ БАЛЛАСТ / ALT AĞIRLIK TAŞLARI / ثقل **J4010**

	H (m)	14	18	22	30	40	46	49
BEX 45 / BTX 45		6		8	10	12	14	14
BEX45L		8		10	12	16	---	---
BEX 38R / BTX 38R		6	8	10	12	---	---	---
BEX 38 / BTX 38		6	8	10	12	---	---	---
BEX 38RL		8	10	12	16	---	---	---
BEX 38L	8	10	12	---	---	---	---	---
BEX 28 / BTX 28 BEX 28L		8	10	12	---	---	---	---
	H (m)	20,3			30,4			
BE 434		8			10			
	H (m)	27,6		31,9		40,3		
BE 442		12		16		20		

H: Altura bajo gancho / Height under hook / Hauteur maximale sous crochet / Высота под крюком / Kanca altı yüksekliği / الارتفاع أسفل الخطاف
 Para alturas intermedias tomar el lastre correspondiente a la altura superior / For intermediate heights take the ballast corresponding to the higher height / Pour les hauteurs intermédiaires, opter pour le lest correspondant à la hauteur immédiatement supérieure / Для промежуточных высот возьмите балласт, соответствующий большей высоте / Orta yükseklikler için daha üst bir yüksekliğe karşılık gelen ağırlığı alınız. / لارتفاعات البينية يرجى استخدام الثقل العائد للارتفاع الأعلى / لارتفاعات البينية يرجى استخدام الثقل العائد للارتفاع الأعلى



Fecha / Date: 28/04/2020

Reservado el derecho a modificaciones sin previo aviso. Declinamos toda responsabilidad derivada de la información proporcionada / Subject to modification, without previous warning. This information is supplied without liability / L'entreprise se réserve le droit de procéder à des modifications sans préavis. Nous déclinons toute responsabilité quant aux informations fournies / Мы оставляем за собой право на внесение изменений без предварительного уведомления. Мы снимаем с себя любую ответственность в отношении предоставленной информации / Önceden bildirilmeksizin değiştirilme hakkı saklıdır. Verilen bilgiler için hiçbir sorumluluk kabul etmemekteyiz / حقوق التغيير محفوظة دون إشعار مسبق. دون أدنى مسؤولية عن المعلومات المقدمة



DENOMINACIÓN / DENOMINATION / DÉSIGNATION / НАЗВАНИЕ / AÇIKLAMA / اسم		L [m]	A [m]	H [m]	P / W [kg]	
Torre Tower	TR 8RM – TR 8M	8,07	1,19	1,19	2575-2515	
Tour	TR 12 – TN 12	12,01	1,19	1,19	2840-2780	
Башня	TR 4	3,96	1,18	1,18	1070	
Kule	TN 4	4,09	1,19	1,19	1055	
برج	TN 2	2,29	1,19	1,19	785	
Conjunto asiento pista, punta de torre, orientación y elevación Slewing table assembly, tower head, slewing and hoisting mechanism Groupe pivot + porte-flèche + mécanisme d'orientation + de levage Сиденье площадки + верхняя секция башни + поворотный механизм + подъемный механизм Göbek +kulenin kafa bölümü+mekanizma+vinç kulesi مجموعة وحدة الدوران + رأس البرج + آلية الدوران + آلية الرفع			6,97	1,65	2,42	3622
Tramo de pluma Jib section	P09 1L (I)	10,13	1	1,15	650	
Troçon de flèche	P09 2L (II)	10,13	0,86	1,09	550	
Секция стрелы	P09 3L (III)	10,15	0,86	1,09	565	
Bom bölümü	P09 4L (IV)	5,26	0,86	1,09	250	
أجزاء الذراع	P09 6L (V)	5,23	0,86	1,03	185	
Polipasto / Hook assembly / Palan / Полуснаст / Kanca takımı / بكرة	SR		0,76	0,16	0,96	135
Carro / Trolley / Chariot / Грузовая тележка / Şaryo / عربة	SR		1	1,33	0,73	110
Contrafluma con plataformas / Counterjib with platforms Contre-flèche avec plateformes / Противовесная консоль с платформами / Platformlu kuçruk / الذراع المقابل مع المنصة			9,95	1,4	0,4	815
Plataforma y cabina / Platform and cabin / Plateforme et cabine Платформа и кабина / Platform ve kabin / منصة وكابينة			3,69	1,63	2,25	820
Contrapeso / Counterweight / Contrepoids / Противовес / Denge ağırlığı / موازن معاكسة / Grande / Big / Grand / Большой / Büyük / كبير / Pequeño / Small / Petit / Малый / Küçük / صغير			1,08	0,50	2,02	2360
			1,08	0,50	1500	
Base grúa Testero largo Crane base Long carriage Base de la grue. Palonnier long Основание крана. Длинная передняя часть Vinç tabanı. Uzun vinç arabası قاعدة الرافعة. مقدمة طويلة (للكابينة)	BTX 28	4,70	0,64	1,53	1346	
	BTX 38	6,11	0,64	1,53	1576	
	BTX 38R	6,11	0,64	1,57	1792	
	BTX 45	7,01	0,64	1,57	2065	
	BTX 28L	6,45	0,55	0,97	1320	
BTX 38L	5,46	0,55	0,97	1160		
BTX 38RL	5,46	0,55	0,88	850		
BTX 45L	4,01	0,55	0,88	660		
BEX 28	4,15	0,3	1,27	1160		
BEX 38	5,56	0,3	1,27	1390		
BEX 38R	5,56	0,3	1,40	1590		
BEX 45	6,55	0,3	1,41	1863		
Mecanismo traslación grúa / Crane travelling mechanism Mécanisme de translation de la grue / Механизм перемещения крана / Yürüyüş mekanizmalı vinç / آلية رفع الرافعة			0,96	0,56	0,66	293
Lastre / Ballast / Lest / Балласт / Alt ağırlık taşları / ثقل	2,8m	3,00	0,44	1,30	3700	
	3,8m	4,00	0,34	1,30	4100	
	4,5m	2,09	0,34	2,10	3450	
	BE 434	3,40	0,34	1,69	4300	
Torre de montaje / Jacking cage / Tour de montage / Монтажная башня / Kaldırma kafesi / برج التركيب		7,14	1,76	1,71	3200	
Torre de montaje sin puerta, carro, plataforma carro y viga de apoyo Jacking cage without door, trolley, trolley platform and beam assembly Tour de montage sans porte, chariot, plateforme de chariot et poutre de soutien Монтажная башня без двери, грузовой тележки, платформы грузовой тележки и опорной балки Kapısız kaldırma kafesi, vinç köprüsü arabası, vinç köprüsü arabası platformu ve giriş takımı برج التركيب بدون بوابة ، وعربة ومنصة متحركة وعارضة تدعيم		TMU 1.18 	7,14	1,76	1,71	2450

T	H	Tower Composition		Tower Composition		H	T		
1	4,5	TN 4	146.32.000	TN 4	4,5	1	TN 4	4,5	1
2	8,5	TN 4		TN 4	8,5	2	TN 4	8,5	2
3	20,3	TN 12	146.31.000	TN 12		3	TN 12		3
4	32,2	TR 12	146.30.000	TR 12		4	TR 12		4
5	40,1	TR 8M	146.30.800	TR 8M		5	TR 8M		5
6	43,9	TX-90/TXXR	202.36.500	TX-90/TXXR		6	TX-90/TXXR		6
7	46,8	T 3-90	133.32.000	T 3-90		7	T 3-90		7
8	49,8	T 3-90		T 3-90		8	T 3-90		8
9	52,7	T 3-90		T 3-90		9	T 3-90		9
		AN 90	133.21.000	AN 90			AN 90		
		AND 90	133.21.800	AND 90			AND 90		
		AN 150	161.21.000	AN 150			AN 150		
		AND 150	161.21.050	AND 150			AND 150		
		AL 20	153.21.800	AL 20			AL 20		
		ALD 20	160.21.250	ALD 20			ALD 20		
		AS 20	160.21.010	AS 20			AS 20		
		ASD 20/24	160.21.080	ASD 20/24			ASD 20/24		
		ASR 20	160.21.200	ASR 20			ASR 20		
		ASRD 20/24	156.21.000	ASRD 20/24			ASRD 20/24		

T: Torre / Tower / Tour / Башни / Kuleler / أبراج
 H: Altura / Height / Hauteur / Высота / Yükseklik / ارتفاع

Otras configuraciones de torre / Other tower configuration / Autres configurations / Прочие конфигурации / Diğer konfigürasyonlar / مكونات أخرى

Transporte
 Transport / Transport /
 Транспортировка / Taşıma /
 نقل

H=38,4 + AN12

2x

3x

≤ 6xTN4

TREPADO / CLIMBING / TÉLESCOPAGE / ЛЕСТНИЦА / TIRMANMA / التسلق J4010

$h_{max}: 3xTR4 + 6xTN4$

h (m)	36
D (m)	5,1 - 10
P (KN)	316 291
Rmax (KN)	142 251

TR4: 800.32.300

Trepado interno / Internal climbing. / Télescopage intérieur / Внутренняя лестница / Bina içi tırmanma / التسلق الداخلي

- Wiento fuera de servicio / Out of service wind / Vitesse du vent hors service / Ветровая нагрузка в покое / Rüzgar devre dışı / الريح خارج الخدمة
- Consultar / Consult / Nous consulter / Консультируйтесь / Danışınız / الرجوع إلى
- En servicio / In service / En service / В работе / Devrede / في الخدمة
- Fuera de servicio / Out of service / Hors service / В покое / Devre dışı / خارج الخدمة



Ctra./Rd. Madrid - Irún Km.415 - 20.213 IDIAZABAL [Gipuzkoa] ESPAÑA / SPAIN
 P.O. Box, 23 - 20.200 BEASAIN - E-mail: jaso@jaso.com
 Tel. +34 943 - 18 70 00 • Fax. +34 943 - 18 70 20
www.jaso.com

Fecha / Date: 28/04/2020

Reservado el derecho a modificaciones sin previo aviso. Declinamos toda responsabilidad derivada de la información proporcionada / Subject to modification, without previous warning. This information is supplied without liability / L'entreprise se réserve le droit de procéder à des modifications sans préavis. Nous déclinons toute responsabilité quant aux informations fournies / Мы оставляем за собой право на внесение изменений без предварительного уведомления. Мы снимаем с себя любую ответственность в отношении предоставленной информации / Onceden bildirilmeksizin değiştirilme hakkı saklıdır. Verilen bilgiler için hiçbir sorumluluk kabul etmemekteyiz / حقوق التغيير محفوظة دون إشعار مسبق. دون أدنى مسؤولية عن المعلومات المقدمة

FEM 1001

DELEGACION / DEALER